

SHELL TYPE NEEDLE ROLLER BEARINGS

Inch Series



Shaft dia. 14.288 – 15.875mm

Shaft dia. mm (inch)	Identification number									
	Standard	Mass (Ref.) g	Closed end	Mass (Ref.) g	Standard	Mass (Ref.) g	Closed end	Mass (Ref.) g	Grease retained	Mass (Ref.) g
14.288 (9/16)	BA 95 Z	4.9	BAM 95	5.8	—	—	—	—	—	—
	BA 96 Z	5.9	BAM 96	6.8	—	—	—	—	—	—
	BA 97 Z	6.9	BAM 97	7.8	—	—	—	—	—	—
	BA 98 Z	7.9	BAM 98	8.9	—	—	—	—	—	—
	BA 910 Z	9.9	BAM 910	10.8	—	—	—	—	—	—
	BA 912 Z	11.7	BAM 912	12.6	—	—	—	—	—	—
	—	—	—	—	—	—	—	—	YB 98	10.1
	—	—	—	—	—	—	—	—	YB 910	12.7
	—	—	—	—	—	—	—	—	YB 912	15.4
	—	—	—	—	BHA 98 Z	11.4	BHAM 98	12.5	—	—
—	—	—	—	BHA 910 Z	13.6	BHAM 910	14.7	—	—	
—	—	—	—	BHA 912 Z	16.3	BHAM 912	17.4	—	—	
15.875 (5/8)	BA 105 Z	5.3	BAM 105	6.5	—	—	—	—	—	—
	BA 107 Z	7.6	BAM 107	8.7	—	—	—	—	—	—
	BA 108 Z	8.7	BAM 108	9.9	—	—	—	—	—	—
	BA 1010 Z	10.8	BAM 1010	12	—	—	—	—	—	—
	BA 1012 Z	12.9	BAM 1012	14	—	—	—	—	—	—
	BA 1014 Z	15.1	BAM 1014	16.2	—	—	—	—	—	—
	BA 1016 Z	17.3	BAM 1016	18.4	—	—	—	—	—	—
	—	—	—	—	—	—	—	—	YB 105	6.7
	—	—	—	—	—	—	—	—	YB 108	11
	—	—	—	—	—	—	—	—	YB 1012	16.9
—	—	—	—	BHA 108 Z	12.6	BHAM 108	13.9	—	—	
—	—	—	—	BHA 1010 Z	14.9	BHAM 1010	16.2	—	—	
—	—	—	—	BHA 1012 Z	18	BHAM 1012	19.3	—	—	
—	—	—	—	BHA 1016 Z	24	BHAM 1016	25	—	—	
—	—	—	—	—	—	—	—	YBH 108	15.3	

Note(1) Allowable rotational speed applies to oil lubrication. For grease lubrication, a maximum of 60% of this value is allowable.  
 Remark Shell Type Grease Retained Full Complement Needle Roller Bearings are provided with prepacked grease. Standard type and closed end type bearings are not provided with prepacked grease, so perform proper lubrication when using these types of bearings.

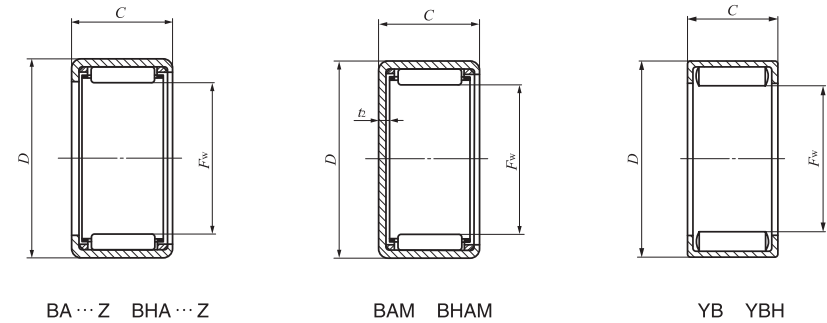

Boundary dimensions mm(inch)				Standard mounting dimensions mm				Basic dynamic load rating	Basic static load rating	Allowable rotational speed(1)	Assembled inner ring
$F_w$	$D$	$C$	$t_2$ Max.	Shaft dia. h6		Housing bore dia. J7		$C$ N	$C_0$ N	min <sup>-1</sup>	
14.288 (9/16)	19.050 (3/4)	7.92 (.312)	1.3	Max.	Min.	Max.	Min.	2 760	2 970	30 000	—
14.288 (9/16)	19.050 (3/4)	9.52 (.375)	1.3	14.288	14.277	19.062	19.041	3 850	4 560	30 000	—
14.288 (9/16)	19.050 (3/4)	11.13 (.438)	1.3	—	—	—	—	4 860	6 140	30 000	—
14.288 (9/16)	19.050 (3/4)	12.70 (.500)	1.3	—	—	—	—	5 220	6 740	30 000	IRB 68
14.288 (9/16)	19.050 (3/4)	15.88 (.625)	1.3	—	—	—	—	7 050	9 910	30 000	—
14.288 (9/16)	19.050 (3/4)	19.05 (.750)	1.3	—	—	—	—	8 690	13 000	30 000	IRB 612
14.288 (9/16)	19.050 (3/4)	12.70 (.500)	—	—	—	—	—	11 600	20 400	11 000	IRB 68
14.288 (9/16)	19.050 (3/4)	15.88 (.625)	—	—	—	—	—	14 300	26 700	11 000	—
14.288 (9/16)	19.050 (3/4)	19.05 (.750)	—	—	—	—	—	16 800	33 000	11 000	IRB 612
14.288 (9/16)	20.638 (13/16)	12.70 (.500)	1.3	14.288	14.277	20.650	20.629	6 380	7 330	30 000	IRB 68
14.288 (9/16)	20.638 (13/16)	15.88 (.625)	1.3	—	—	—	—	9 280	11 900	30 000	—
14.288 (9/16)	20.638 (13/16)	19.05 (.750)	1.3	—	—	—	—	11 600	15 900	30 000	IRB 612
15.875 (5/8)	20.638 (13/16)	7.92 (.312)	1.3	15.875	15.864	20.650	20.629	2 870	3 220	25 000	—
15.875 (5/8)	20.638 (13/16)	11.13 (.438)	1.3	—	—	—	—	5 040	6 660	25 000	—
15.875 (5/8)	20.638 (13/16)	12.70 (.500)	1.3	—	—	—	—	5 420	7 310	25 000	IRB 68-1
15.875 (5/8)	20.638 (13/16)	15.88 (.625)	1.3	—	—	—	—	7 320	10 700	25 000	—
15.875 (5/8)	20.638 (13/16)	19.05 (.750)	1.3	—	—	—	—	9 020	14 100	25 000	IRB 612-1
15.875 (5/8)	20.638 (13/16)	22.22 (.875)	1.3	—	—	—	—	10 700	17 500	25 000	IRB 714
15.875 (5/8)	20.638 (13/16)	25.40 (1.000)	1.3	—	—	—	—	12 300	20 800	25 000	IRB 716
15.875 (5/8)	20.638 (13/16)	7.92 (.312)	—	—	—	—	—	7 580	12 200	9 500	—
15.875 (5/8)	20.638 (13/16)	12.70 (.500)	—	—	—	—	—	12 300	22 700	9 500	IRB 68-1
15.875 (5/8)	20.638 (13/16)	19.05 (.750)	—	—	—	—	—	17 800	36 600	9 500	IRB 612-1
15.875 (5/8)	22.225 (7/8)	12.70 (.500)	1.3	15.875	15.864	22.237	22.216	6 680	8 020	25 000	IRB 68-1
15.875 (5/8)	22.225 (7/8)	15.88 (.625)	1.3	—	—	—	—	10 200	13 800	25 000	—
15.875 (5/8)	22.225 (7/8)	19.05 (.750)	1.3	—	—	—	—	12 700	18 500	25 000	IRB 612-1
15.875 (5/8)	22.225 (7/8)	25.40 (1.000)	1.3	—	—	—	—	17 400	27 600	25 000	IRB 716
15.875 (5/8)	22.225 (7/8)	12.70 (.500)	—	—	—	—	—	15 000	22 400	9 500	IRB 68-1